



TRUE MANUFACTURING CO., INC.  
U.S.A. FOODSERVICE DIVISION

2001 East Terra Lane • O'Fallon, Missouri 63366-4434 • (636)240-2400  
Fax (636)272-2408 • Toll Free (800)325-6152 • Intl Fax# (001)636-272-7546  
Parts Dept. (800)424-TRUE • Parts Dept. Fax# (636)272-9471 • www.truemfg.com

Project Name: \_\_\_\_\_

Location: \_\_\_\_\_

Item #: \_\_\_\_\_ Qty: \_\_\_\_\_

Model #: \_\_\_\_\_

A/A #

S/S #

Model:

**TUC-48G-HC~SPEC3**

**Undercounter:**

*Glass Door Refrigerator with Hydrocarbon Refrigerant~Spec Package 3*



## TUC-48G-HC~SPEC3

- ▶ True's undercounter units are designed with enduring quality that protects your long term investment.
- ▶ Designed using the highest quality materials and components to provide the user with colder product temperatures, lower utility costs, exceptional food safety and the best value in today's food service marketplace.
- ▶ Factory engineered, self-contained, capillary tube system using environmentally friendly R290 hydro carbon refrigerant that has zero (0) ozone depletion potential (ODP), & three (3) global warming potential (GWP).
- ▶ High capacity, factory balanced refrigeration system that maintains cabinet temperatures of 33°F to 38°F (5°C to 3.3°C) for the best in food preservation.
- ▶ Stainless steel front, countertop, sides, and back.
- ▶ Interior - Stainless steel liner. Stainless steel floor with coved corners.
- ▶ Heavy duty 16 gauge top.
- ▶ Lifetime guaranteed heavy duty all metal working spec door handle.
- ▶ Counter-Top front is flush with front of doors.
- ▶ Electronic temperature control with digital display.
- ▶ Foamed-in-place using a high density, polyurethane insulation that has zero ozone depletion potential (ODP) and zero global warming potential (GWP).
- ▶ Spec Series® logo

## ROUGH-IN DATA

Chart dimensions rounded up to the nearest 1/8" (millimeters rounded up to next whole number). Specifications subject to change without notice.

| Model            | Doors | Shelves | Cabinet Dimensions (inches) (mm) |               |               | HP         | Voltage                  | Amps       | NEMA Config. | Cord Length (total ft.) (total m) | Crated Weight (lbs.) (kg) |
|------------------|-------|---------|----------------------------------|---------------|---------------|------------|--------------------------|------------|--------------|-----------------------------------|---------------------------|
|                  |       |         | W                                | D†            | H*            |            |                          |            |              |                                   |                           |
| TUC-48G-HC~SPEC3 | 2     | 4       | 48 3/8<br>1227                   | 29 3/8<br>751 | 29 3/4<br>762 | 1/2<br>1/2 | 115/60/1<br>230-240/50/1 | 3.0<br>1.3 | 5-15P        | 7<br>2.13                         | 315<br>143                |

† Depth does not include 1 1/2" (39 mm) for door handles. † Depth does not include 1" (26 mm) for rear bumpers and 1/8" (4 mm) for door handle.

\* Height does not include 6 1/4" (159 mm) for castors or 6" (153 mm) for optional legs.



APPROVALS:

AVAILABLE AT:

Model:  
**TUC-48G-HC~SPEC3**

**Undercounter:**  
*Glass Door Refrigerator with Hydrocarbon Refrigerant~Spec Package 3*



**STANDARD FEATURES**

**DESIGN**

- True's commitment to using the highest quality materials and oversized refrigeration systems provides the user with colder product temperatures, lower utility costs, exceptional food safety and the best value in today's food service marketplace.

**REFRIGERATION SYSTEM**

- Factory engineered, self-contained, capillary tube system using environmentally friendly R290 hydrocarbon refrigerant that has zero (0) ozone depletion potential (ODP), & three (3) global warming potential (GWP).
- Energy efficient, factory balanced refrigeration system with guided airflow to provide uniform product temperatures.
- High capacity, factory balanced refrigeration system that maintains cabinet temperatures of 33°F to 38°F (.5°C to 3.3°C) for the best in food preservation.
- State of the art, electronically commutated evaporator and condenser fan motors. ECM motors operate at higher peak efficiencies and move a more consistent volume of air which produces less heat, reduces energy consumption and provides greater motor reliability.
- Condensing unit access in back of cabinet, slides out for easy maintenance.

**CABINET CONSTRUCTION**

- Exterior - stainless steel front, top, sides, and back.
- Interior - Stainless steel liner. Stainless steel floor with coved corners.

- Insulation - entire cabinet structure is foamed-in-place using a high density, polyurethane insulation that has zero ozone depletion potential (ODP) and zero global warming potential (GWP).
- 5" (127 mm) diameter stem castors - locks provided on front set. 36" (915 mm) work surface height.

**DOORS**

- "Low-E", double pane thermal insulated glass assembly with extruded aluminum frames.
- Door locks standard.
- Lifetime guaranteed heavy duty all metal working spec door handles.
- Positive seal self-closing doors. Doors swing within cabinet dimensions.
- Magnetic door gaskets of one piece construction, removable without tools for ease of cleaning.

**SHELVING**

- Four (4) adjustable, heavy duty PVC coated wire shelves 21 5/16" L x 16"D (548 mm x 407 mm). Four (4) chrome plated shelf clips included per shelf.
- Shelf support pilasters made of same material as cabinet interior; shelves are adjustable on 1/2" (13 mm) increments.

**LIGHTING**

- LED interior lighting provides more even lighting throughout the cabinet. Safety shielded.

**MODEL FEATURES**

- Evaporator is epoxy coated to eliminate the potential of corrosion.
- Heavy duty 16 gauge top.
- Counter-Top front is flush with front of doors.

- Electronic temperature control with digital display.
- Spec Series® logo.
- NSF/ANSI Standard 7 compliant for open food product.

**ELECTRICAL**

- Unit completely pre-wired at factory and ready for final connection to a 115/60/1 phase, 15 amp dedicated outlet. Cord and plug set included.



115/60/1  
NEMA-5-15R

**OPTIONAL FEATURES/ACCESSORIES**

Upcharge and lead times may apply.

- 230 - 240V / 50 Hz.
- 6" (153 mm) standard legs.
- 6" (153 mm) seismic/flanged legs.
- 2 1/2" (64 mm) diameter castors.
- Single overshelf.
- Double overshelf.
- TUC-27 Stacking collar.
- Cutting boards provided by others. Requires "L" brackets. Field installed brackets provided by True (contact factory).
- ADA compliant models with 34" (864 mm) work surface height.
- Low profile models with 31 7/8" (810 mm) work surface height.

**PLAN VIEW**

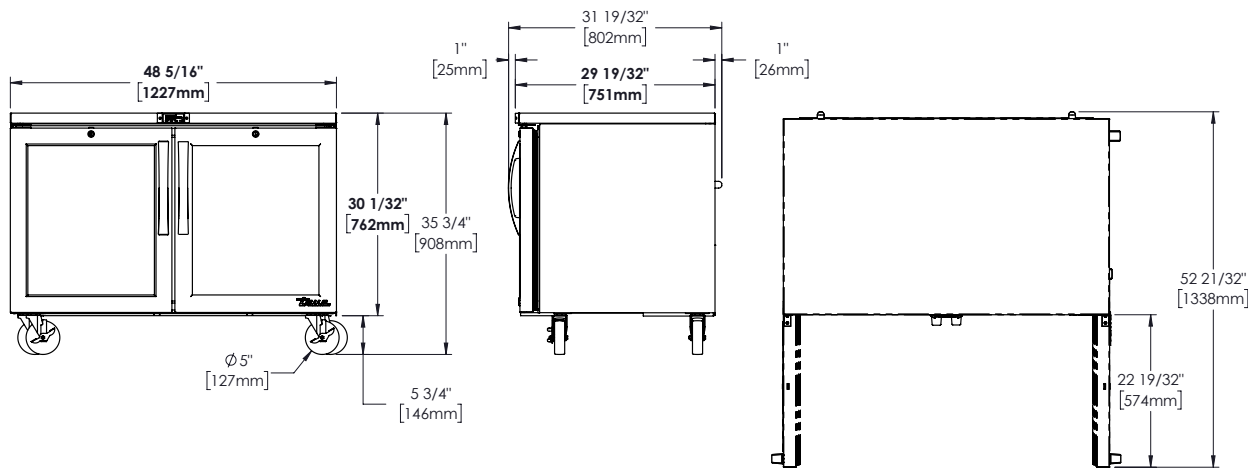

**3 YEAR PARTS + LABOR** **7 YEAR COMPRESSOR**

**WARRANTY**  
(U.S.A. and Canada only)

METRIC DIMENSIONS ROUNDED UP TO THE NEAREST WHOLE MILLIMETER

SPECIFICATIONS SUBJECT TO CHANGE WITHOUT NOTICE



|                  |           |       |      |    |      |
|------------------|-----------|-------|------|----|------|
| Model            | Elevation | Right | Plan | 3D | Back |
| TUC-48G-HC~SPEC3 |           |       |      |    |      |

**TRUE MANUFACTURING CO., INC.**