



TRUE MANUFACTURING CO., INC.
U.S.A. FOODSERVICE DIVISION

2001 East Terra Lane • O'Fallon, Missouri 63366-4434 • (636)240-2400
 Fax (636)272-2408 • Toll Free (800)325-6152 • Intl Fax# (001)636-272-7546
 Parts Dept. (800)424-TRUE • Parts Dept. Fax# (636)272-9471 • www.truemfg.com

Project Name: _____

Location: _____

Item #: _____ Qty: _____

Model #: _____

A/A #

S/S #

Model:

TSD-09G-HC-LD

TSD Series:

Reach-In Glass Slide Door Refrigerator with Hydrocarbon Refrigerant & LED Lighting



TSD-09G-HC-LD

- ▶ True's glass door reach-in's are designed with enduring quality that protects your long term investment.
- ▶ Designed using the highest quality materials and components to provide the user with colder product temperatures, lower utility costs, exceptional food safety and the best value in today's food service marketplace.
- ▶ Factory engineered, self-contained, capillary tube system using environmentally friendly R290 hydro carbon refrigerant that has zero (0) ozone depletion potential (ODP), & three (3) global warming potential (GWP).
- ▶ Energy efficient, factory balanced, refrigeration system holds 33°F to 38°F (5°C to 3.3°C) for the best in food preservation.
- ▶ Exterior - high quality stainless steel front, sides, back, and top.
- ▶ Interior - attractive, NSF approved, clear coated aluminum liner. Stainless steel floor with coved corners.
- ▶ Self closing doors. Counter-balanced weight system for smooth, even, positive closing.
- ▶ "Low-E", double pane thermal insulated glass door assemblies. The latest in energy efficient technology.
- ▶ LED interior lighting provides more even lighting throughout the cabinet. Safety shielded.
- ▶ Entire cabinet structure is foamed-in-place using a high density, polyurethane insulation that has zero ozone depletion potential (ODP) and zero global warming potential (GWP).

ROUGH-IN DATA

Specifications subject to change without notice.
 Chart dimensions rounded up to the nearest 1/8" (millimeters rounded up to next whole number).

Model	Doors	Shelves	Cabinet Dimensions (inches) (mm)			HP	Voltage	Amps	NEMA Config.	Cord Length (total ft.) (total m)	Crated Weight (lbs.) (kg)
			W	D†	H						
TSD-09G-HC-LD	2	3	36 913	21 532	35 7/8 911	1/8 1/8	115/60/1 230-240/50/1	1.9 1.5	5-15P ▲	9 2.74	280 127

† Depth does not include 3/8" (23 mm) for door handles or 1/2" (13 mm) for system mechanical components.

▲ Plug type varies by country.



APPROVALS:

AVAILABLE AT:

Model:
TSD-09G-HC-LD

TSD Series:
*Reach-In Glass Slide Door Refrigerator with
Hydrocarbon Refrigerant & LED Lighting*



STANDARD FEATURES

DESIGN

- True's sliding door reach-in's are designed with enduring quality that protects your long term investment.
- True's commitment to using the highest quality materials and oversized refrigeration systems provides the user with colder product temperatures, lower utility costs, exceptional food safety and the best value in today's food service marketplace.

REFRIGERATION SYSTEM

- Factory engineered, self-contained, capillary tube system using environmentally friendly R290 hydro carbon refrigerant that has zero (0) ozone depletion potential (ODP), & three (3) global warming potential (GWP).
- High capacity, factory balanced refrigeration system that maintains cabinet temperatures of 33°F to 38°F (.5°C to 3.3°C) for the best in food preservation.
- State of the art, electronically commutated evaporator and condenser fan motors. ECM motors operate at higher peak efficiencies and move a more consistent volume of air which produces less heat, reduces energy consumption and provides greater motor reliability.

CABINET CONSTRUCTION

- Exterior - high quality stainless steel front, sides, back, and top.
- Interior - attractive, NSF approved, clear coated aluminum liner. Stainless steel floor with coved corners.
- Insulation - entire cabinet structure is foamed-in-place using a new, innovative, high density, polyurethane insulation that has zero ozone depletion potential (ODP) and zero global warming potential (GWP).
- Welded, heavy duty steel frame rail, black powder coated for corrosion protection.
- Cabinet fitted with leg levelers.

DOORS

- "Low-E", double pane thermal glass insert with mitered plastic channel frame.
- Each door fitted with 12" (305 mm) long handle.
- Self-closing doors, efficient counter balanced weight system for smooth, even, positive closing.

SHELVING

- Three (3) adjustable, heavy duty PVC coated wire shelves: two (2) 31 3/4" x 13 9/16" (807 mm x 345 mm) and one (1) 31 3/4" x 7 1/2" (807 mm x 191 mm). Four (4) chrome plated shelf clips included per shelf.

- Shelf support pilasters made of same material as cabinet interior; shelves are adjustable on 1/2" (13 mm) increments.

LIGHTING

- LED interior lighting provides more even lighting throughout the cabinet. Safety shielded.

MODEL FEATURES

- Evaporator is epoxy coated to eliminate the potential of corrosion.
- NSF/ANSI Standard 7 compliant for open food product.

ELECTRICAL

- Unit completely pre-wired at factory and ready for final connection to a 115/60/1 phase - 15 amp dedicated outlet. Cord and plug set included.



115/60/1
NEMA-5-15R

OPTIONAL FEATURES/ACCESSORIES

Upcharge and lead times may apply.

- 230 - 240V / 50 Hz.
- Ratchet locks
- Barrel locks
- Gravity feed 20 oz. bottle display system.
- Additional Shelves

PLAN VIEW

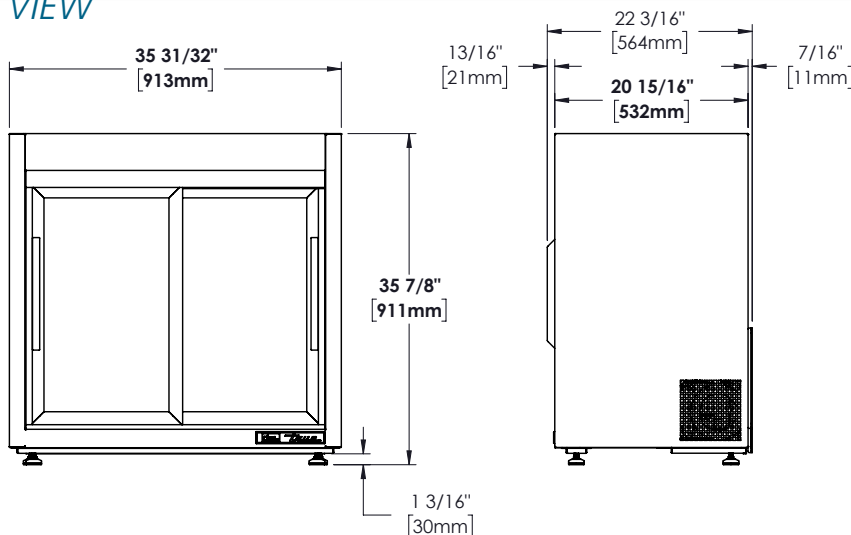

METRIC DIMENSIONS ROUNDED UP TO THE NEAREST WHOLE MILLIMETER

SPECIFICATIONS SUBJECT TO CHANGE WITHOUT NOTICE



Model	Elevation	Right	Plan	3D	Back
TSD-09G-HC-LD					

TRUE MANUFACTURING CO., INC.

2001 East Terra Lane • O'Fallon, Missouri 63366-4434 • (636)240-2400 • Fax (636)272-2408 • Toll Free (800)325-6152 • Intl. Fax# (001)636-272-7546 • www.truefmfg.com