



TRUE MANUFACTURING CO., INC.  
U.S.A. FOODSERVICE DIVISION

2001 East Terra Lane • O'Fallon, Missouri 63366-4434 • (636)240-2400  
Fax (636)272-2408 • Toll Free (800)325-6152 • Intl Fax# (001)636-272-7546  
Parts Dept. (800)424-TRUE • Parts Dept. Fax# (636)272-9471 • www.truemfg.com

Project Name: \_\_\_\_\_

Location: \_\_\_\_\_

Item #: \_\_\_\_\_ Qty: \_\_\_\_\_

Model #: \_\_\_\_\_

A/A #

SIS #

Model:  
**TH-23**

**TH Series:**  
*Reach-In Solid Swing Door Heated Cabinet*



## TH-23

- ▶ Provides cabinet holding temperature of 80°F to 180°F (26.6°C to 82.2°C).
- ▶ Internal fan provides low velocity, forced-air heat distribution to assure even temperatures throughout the cabinet.
- ▶ Stainless steel, tube heating element for uniform generation of electric heat. Cabinet comes with a total of 850 watts. Heating element sheathed for corrosion resistance.
- ▶ Exterior - stainless steel front and door. Anodized quality aluminum ends. Corrosion resistant GalFan coated steel back.
- ▶ Interior - Stainless steel interior liner and floor.
- ▶ Cabinet comes standard with three (3), adjustable, heavy duty chrome plated wire shelves.
- ▶ Entire cabinet structure and solid door are foamed-in-place using a high density, polyurethane insulation that has zero ozone depletion potential (ODP) and zero global warming potential (GWP).

## ROUGH-IN DATA

Specifications subject to change without notice.  
Chart dimensions rounded up to the nearest 1/8" (millimeters rounded up to next whole number).

Model	Doors	Cabinet Dimensions (inches) (mm)			Watts	Voltage	Amps	NEMA Config.	Cord Length (total ft.) (total m)	Crated Weight (lbs.) (kg)
		W	D	H*						
TH-23	1	27 686	29½ 750	78¾ 1991	850	115/60/1	7.8 N/A	5-15P	9 2.74	260 118

\* Height does not include 5" (127 mm) for castors or 6" (153 mm) for optional legs.

\* Height does not include 1" (26 mm) for ventilator cap.



APPROVALS:

AVAILABLE AT:

Model:  
**TH-23**

**TH Series:**  
*Reach-In Solid Swing Door Heated Cabinet*

**True**

## STANDARD FEATURES

### DESIGN

- True's solid door reach-in heated cabinets are designed with enduring quality that protects your long term investment.

### HEATER SYSTEM

- Cabinet is designed to provide holding temperatures of 80°F to 180°F (26.6°C to 82.2°C). Heating system controlled by exterior on/off switch and temperature control dial.
- Stainless steel, tube heating element for uniform generation of electric heat. Cabinet comes with a total of 850 watts. Heating element sheathed for corrosion resistance.
- Low-velocity fans to assure even temperature distribution throughout the cabinet.
- Manually controlled vent located on top of the cabinet for positive humidity control.
- Exterior dial thermometer; accurate, direct reading of internal cabinet temperature.

### CABINET CONSTRUCTION

- Exterior - Stainless steel front. Anodized quality aluminum ends. Corrosion resistant GalFan coated steel back.
- Interior- Stainless steel interior liner and floor.
- Insulation - entire cabinet structure and solid door are foamed-in-place using a high density, polyurethane insulation that has zero ozone depletion potential (ODP) and zero global warming potential (GWP).

- Welded, heavy duty steel frame rail, black powder coated for corrosion protection.
- Frame rail fitted with 4" diameter stem castors - locks provided on front set.

### DOOR

- Stainless steel exterior and liner. Door opens within cabinet dimension. Door lock standard.
- Lifetime guaranteed recessed door handle standard. Door fitted with 12" long recessed handle that is foamed-in-place with a sheet metal interlock to ensure permanent attachment.
- Positive seal self-closing door. Lifetime guaranteed door hinges and torsion type closure system.
- Magnetic door gasket of one piece construction, removable without tools for ease of cleaning.

### SHELVING

- Three (3) adjustable, heavy duty chrome plated wire shelves 21 <sup>7</sup>/<sub>16</sub>" L x 23 <sup>1</sup>/<sub>4</sub>" D (545 mm x 591 mm). Four (4) chrome plated shelf clips included per shelf.
- Anodized aluminum shelf support pilasters. Shelves are adjustable on <sup>1</sup>/<sub>2</sub>" (13 mm) increments.

### LIGHTING

- Interior lighting; safety shielded.

### MODEL FEATURES

- 12"L x 20"W x 1"D (305 mm x 508 mm x 26 mm) humidity pan standard for contents requiring high humidity.

- True heated cabinets are designed to hold warm baked or cooked food. Cabinets are not designed to heat ambient or cold products.
- NSF/ANSI Standard 4 compliant for open food product.

### ELECTRICAL

- True requires that a sole use circuit be dedicated for the unit.
- Unit completely pre-wired at factory and ready for final connection to a 115/60/1 phase, 15 amp dedicated outlet. Cord and plug set included.



115/60/1  
NEMA-5-15R

### OPTIONAL FEATURES/ACCESSORIES

Upcharge and lead times may apply.

- 6" (153 mm) standard legs.
- 6" (153 mm) seismic/flanged legs.
- Alternate door hinging (factory installed).
- Additional shelves.
- Half door bun tray racks. Each holds up to eleven 18"L x 26"D (458 mm x 661 mm) sheet pans (sold separately).
- Full door bun tray rack. Holds up to twenty-two 18"L x 26"D (458 mm x 661 mm) sheet pans (sold separately).

## PLAN VIEW

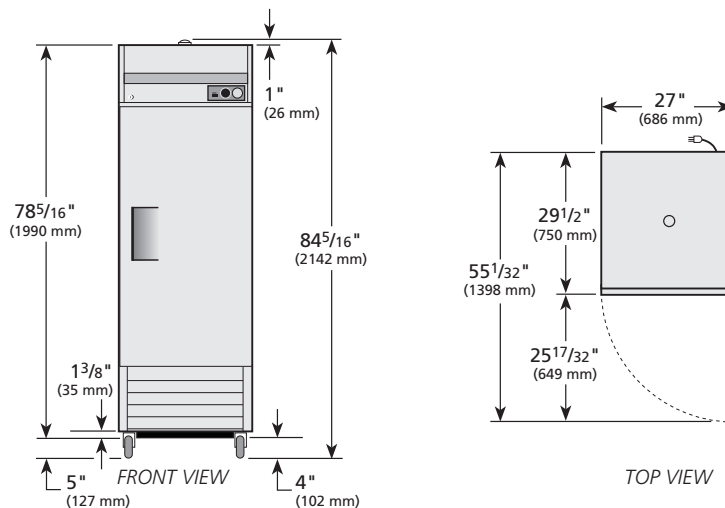

METRIC DIMENSIONS ROUNDED UP TO THE NEAREST WHOLE MILLIMETER

SPECIFICATIONS SUBJECT TO CHANGE WITHOUT NOTICE



Model	Elevation	Right	Plan	3D	Back
TH-23					

**TRUE MANUFACTURING CO., INC.**

2001 East Terra Lane • O'Fallon, Missouri 63366-4434 • (636)240-2400 • Fax (636)272-2408 • Toll Free (800)325-6152 • Intl. Fax# (001)636-272-7546 • www.truefmfg.com