

TRM™ Series

True Retail Merchandisers

true
REFRIGERATION

A unique approach to large format refrigeration.





Going Green

is easier than ever with True's new large format self-contained retail merchandiser (TRM).

The TRM's unique high performance modular hydrocarbon R290 refrigeration system is designed for reliability, energy efficiency, and ease of install.

Enjoy the large capacity product storage combined with a future proof refrigeration solution designed exclusively for retail applications.

As high GWP refrigerant regulatory pressures intensify, the need to adopt sustainable practices has become not just an ethical choice but a fundamental strategy.

True's Retail Merchandisers are a sustainable self-contained large format refrigeration solution.





reliable
energy efficient
ease of install



TRM's are a unique approach to large format refrigeration.

Enjoy the capacity of remotely powered refrigeration with self-contained convenience.

Grocery and convenience retailers can now strategically leverage self-contained refrigeration systems with superior advantages over traditional remote systems.





Pros of TRM self-contained refrigeration...

- Low GWP hydrocarbon (R290) refrigeration systems are future proof and exempt from EPA and state refrigeration regulations.
- Easy Installation. No need to run refrigerant lines to a remote condensing unit.
- Factory sealed variable speed refrigeration systems prevent refrigeration leaks.
- No need for expensive refrigeration techs for cabinet install.
- High efficiency Energy Star approved models. Utility rebates available.
- True's Dynamic Refrigeration Response System™ offers high performance cooling at Energy Star levels.
- Refrigeration redundancy prevents down time and product loss.



Get ahead of **HFC** and **High GWP** refrigerant phaseouts.

With regulatory pressures mounting to phase out HFC and high GWP refrigerants, the TRM series unique R290 hydrocarbon refrigeration system are a great option that doesn't sacrifice what is important to retail refrigeration.

HFC Regulations

- **EPA's AIM Act** - Aggressive timeline for HFC Phase-down. Reducing HFC production availability and facilitating the transition to low GWP refrigerants.
- **EPA's new Technology Transitions Program** - Restricts the use of higher GWP HFC refrigerants in retail food refrigeration equipment. Restrictions begin as soon as January 1, 2025 for stand-alone equipment. Restrictions begin January 1, 2026 for retail food supermarket equipment.

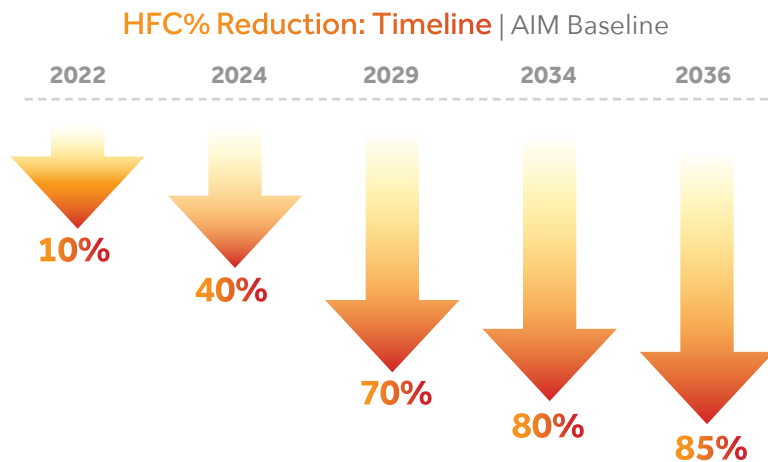

What effect will the **HFC** phaseout have on commercial refrigeration?

- Prices of HFC refrigerants will continue to increase.
- Availability of HFC refrigerants will become scarce.
- Low GWP refrigerants like R290 will be critical moving forward.

Future Proof Refrigerant – R290

Retailers now have a solution that sets an industry standard for sustainable merchandising with the first eco-friendly large format merchandiser.

Global Warming Potential of Refrigerants

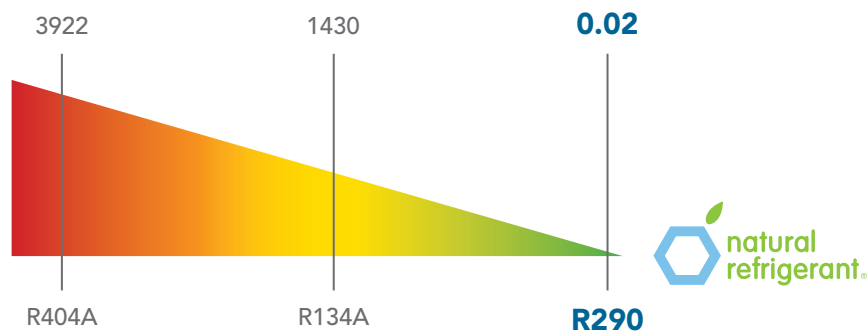

With R290, you get a simplified solution

R290 refrigerant has revolutionized the way retailers operate. HFC refrigerants pose a high threat to the atmosphere while offering no benefits. Eco-conscious refrigerants (R290) modernize operations by:

- Lowering energy consumption and meeting Energy Star standards.
- No ozone-depleting properties.
- EPA and state regulatory exemptions.
- Modular floor plans offer retail flexibility.

80%
Less Refrigerant
Needed*

*Compared to current HFC hybrid units.



TRM Energy Performance

KwH Savings Below Energy Star® Standards

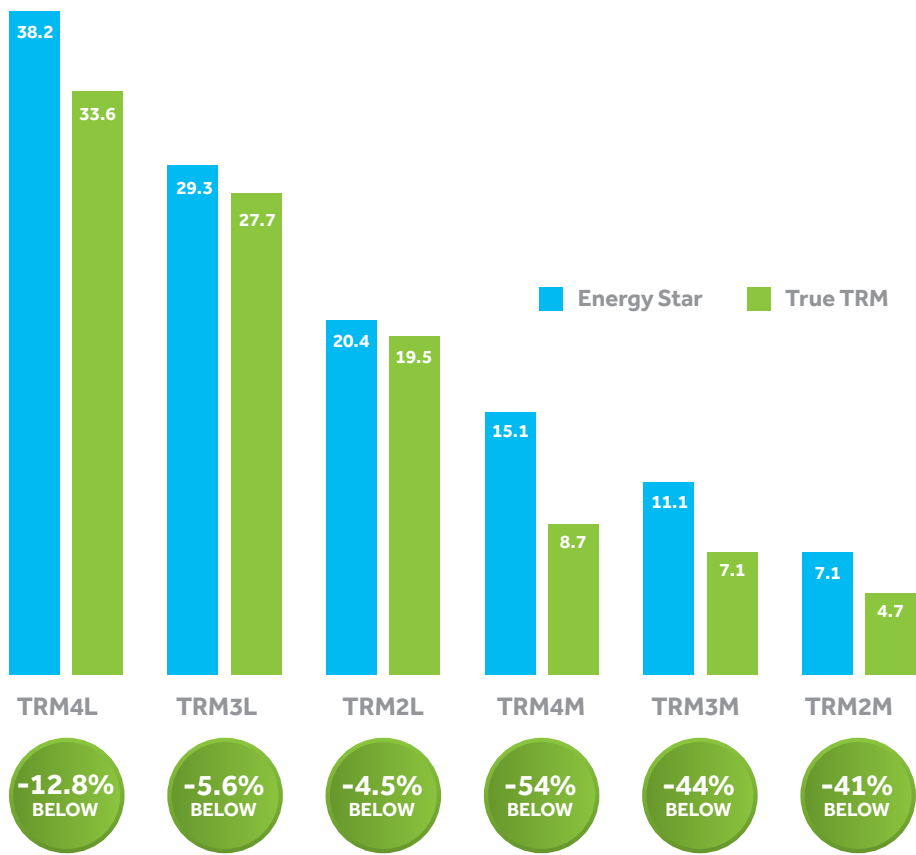

TRM's Energy Star ratings qualify for many utility rebate programs across the country.



GRAB-N-GO



WE SELL
ENERGY STAR

Redefining standards for high performance.

With its advanced technology and innovative design, the TRM Series not only outperforms traditional models but also takes the lead in environmental responsibility.

- **R290** future proof refrigerant.
- Meets **Energy Star** standards and DOE listed as a self-contained product.
- **18% more interior volume** compared to traditional cases.
- Factory charged, **self-contained sealed refrigeration system** for reliability.
- **Self-cleaning (RCU) condenser technology** provides sustained energy consumption and reliability.
- Patented **True Level™ Leveling System** to ease installation.
- The **True Dynamic Refrigeration Response System™**
Refrigeration capacity is adjusted based on demand.



3 YEAR 3 YEAR 3 YEAR
LABOR PARTS COMPRESSOR
WARRANTY

Loss prevention solution for retailers.

The True Dynamic Refrigeration Response System™ boasts unmatched efficiency and cutting-edge technology, ensuring consistent temperatures where and when cooling is needed. The TRM refrigeration architecture offers a unique refrigeration redundancy system reducing down time and product loss (excludes TRM2M).

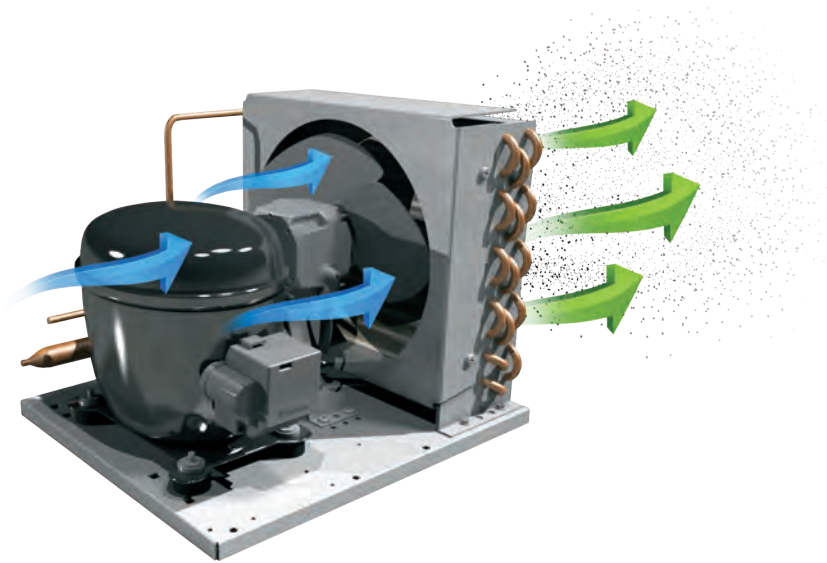

Self-cleaning condenser technology.

With its innovative design, True's Self-Cleaning Condenser Technology works by reversing the fan direction upon each startup of the unit, which causes the airflow to blow through the condensing coil and effectively removes any dirt, dust, or debris.

- Eliminates the need to clean the condenser.



Scan for more info

20%
Less Energy Consumption!

Coldest
Temps
Freshest
Products!

Increased
Life
Span!

TRM Features

- **70" viewable glass height** to ensure maximum product display.
- Industry standard **30" wide cantilever shelves**.
- **Cabinet depth** designed strategically at 38 $\frac{7}{8}$ ".
- Non-marking **floor gliders**.
- **Built-in leveling system** (True Level™).
- Factory charged **Self-contained Refrigeration System**.
- **Large 28" deep bottom shelf**.
- **No lower interior evaporator** – No need for an interior condensate pump. No clogged drains or condensate hose.
- **Easy to install** – No refrigeration technician needed.
- **Plug-and-play** – Self-contained modular future-proof refrigeration solution.
- **Fits through 84" door casing**.



TRM2L | 2M

Game Changing, Large Format Refrigeration!

Factory Sealed Modular R290 Condenser Deck.

Cabinet Clearance
Fits through 84" door casing.

70" Viewable Glass Height
Ensures maximum product display.

Case Depth 38 $\frac{7}{8}$ "

White Interior

Shelf Width 30"

Shelf Depth
Cantilever shelf: 25"
Bottom shelf: 28"+

26 $\frac{1}{2}$ " Viewable Glass Width

True Level™ Leveling System

Non-Marking Floor Gliders



TRM3L | 3M



TRM4L | 4M

1

2

3

TRM Installation

TRM Installation

The TRM Series is True's modern day large format refrigeration system.

Our TRM cabinets are a game changer when it comes to ease of installation. Once the unit is uncrated, it can easily be moved into position due to our non-marking floor glides. Two people using basic tools can complete the installation, no need for a service or refrigeration technician.

In just a few easy steps, your True TRM cabinets can be up and running and beautifully showcasing your product offering like never before!



Step 1: Uncrate & Move

Uncrate by removing simple packaging and move unit into final location utilizing sliders or any typical moving devices.

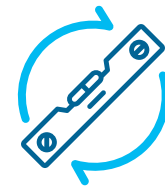

Step 2: Level the Unit(s)

Level the unit by utilizing our True Level™ system.

Easy Installation in Your Current Space!

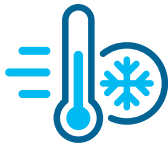

Step 3: Install Refrigeration

Install refrigeration deck on top of the cabinet utilizing simple everyday tools and supplied hardware.



Step 4: Finishing Touches

Install shrouds, kick plates, bottom shelves, and dividers.

TRM Nomenclature

Model

TRM | True Retail Merchandiser

Cabinet Variation

L | Low (6° F to -10° F)
M | Medium (32° F to 41° F)
MS | Medium temp + Seismic
LS | Low temp + Seismic

Cabinet Exterior

BLK | Black (027)

TRM3L-YY-BLK-

Sections/Doors

2 | Doors
3 | Doors
4 | Doors

End Panel Type

YY | In line left panel / In line right panel
YN | In line left panel / Finished right panel
NY | Finished left panel / In line right panel
NN | Finished left panel / Finished right panel



Interior Finish

- BLK | Black (027)
- WHT | White (110)

Hinging

- L | All Left
- R | All Right
- NO | L / R Combo

- WHT - 1 BLK LLL - 4

Door Frame Style/Color

- 1BLK | Black (027)

Lighting

- 4 | 4000K LED

panel
panel
panel



TRM Plan Views

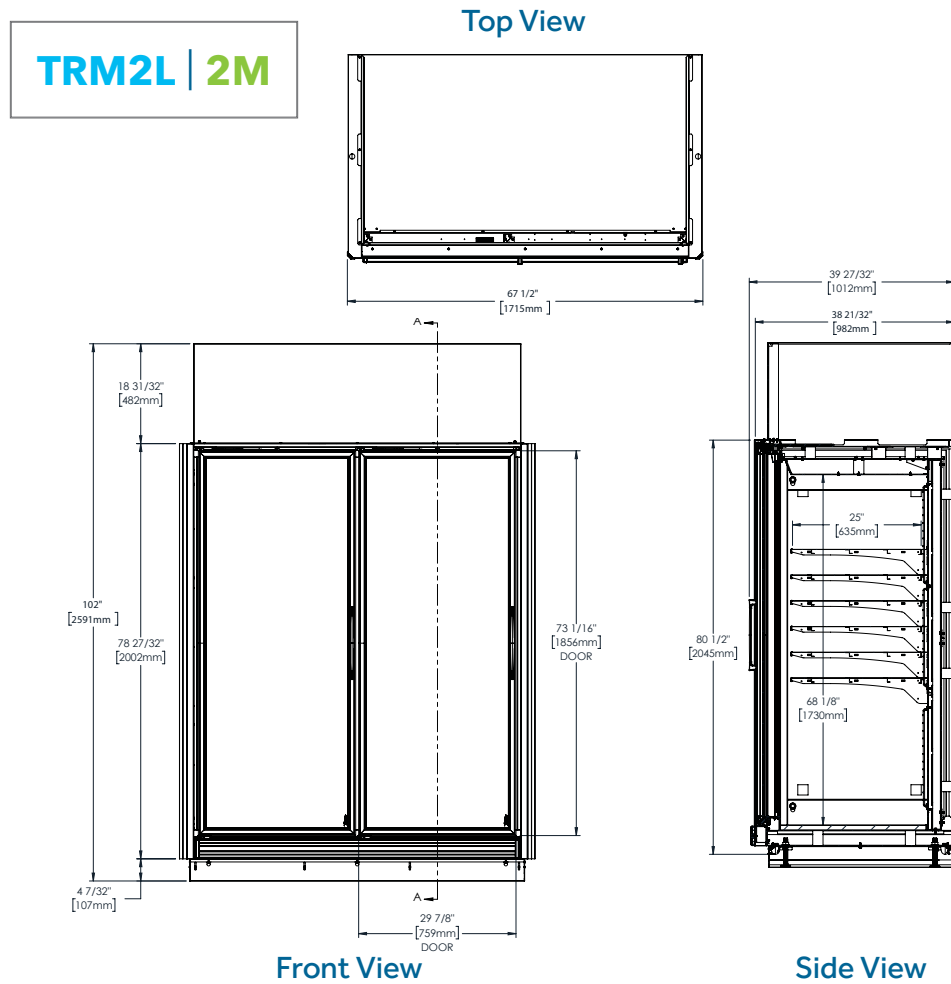

TRM Specifications



TRM2L

Cabinet Exterior Dimensions	W	D †	H
	67 1/2"	38 7/8"	102"
Internal Dimensions	62 1/2"	28"	68 1/8"
Temperature	-10° F / 6° F		
Voltage	HP (per deck)	Amps	NEMA
	(1 1/4) 2 1/2	13.8	NEMA-L6-20P
Doors	2		
Shelves	10		

Low Temp



TRM2M

Cabinet Exterior Dimensions	W	D †	H
	67 1/2"	38 7/8"	102"
Internal Dimensions	62 1/2"	28"	68 1/8"
Temperature	32° F / 41° F		
Voltage	HP (per deck)	Amps	NEMA
	(3/4) 1 1/2	5.3	NEMA-L6-15P
Doors	2		
Shelves	10		

Medium Temp

(NOTE: plan views show NN configuration.)

TRM3L | 3M

Top View

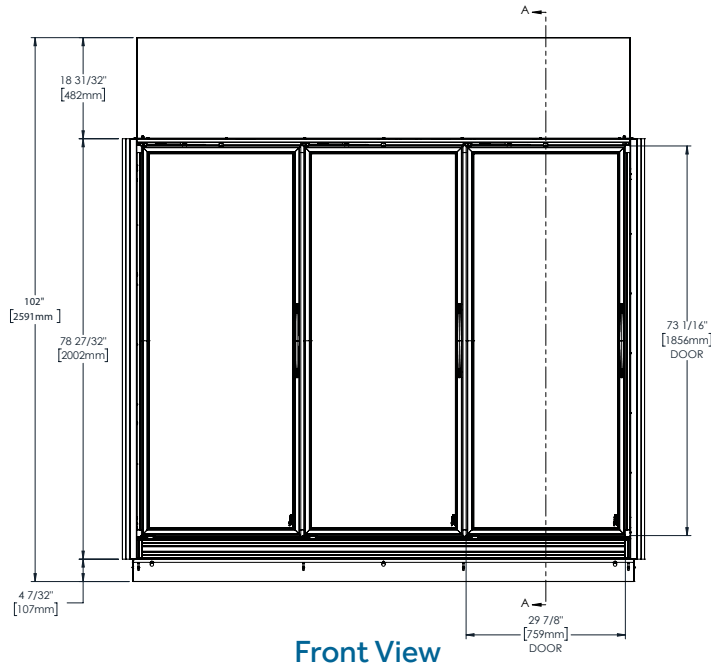
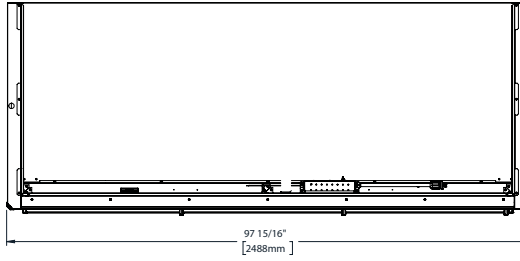

Front View

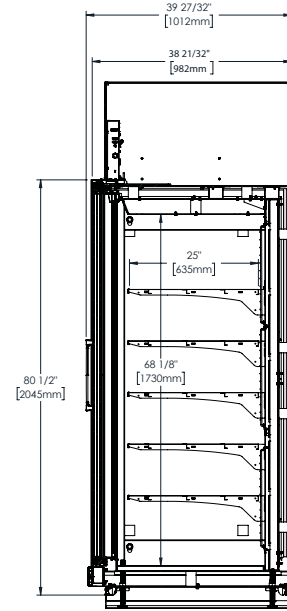

Side View



TRM3L

Cabinet Exterior Dimensions	W	D †	H
	97 15/16"	38 7/8"	102"
Internal Dimensions	92 5/8"	28"	68 1/8"
Temperature	-10°F / 6°F		
Voltage	HP (per deck)	Amps	NEMA
	(1¼) 2½	13.8	NEMA-L6-20P
Doors	3		
Shelves	15		

Low Temp



TRM3M

Cabinet Exterior Dimensions	W	D †	H
	97 15/16"	38 7/8"	102"
Internal Dimensions	92 5/8"	28"	68 1/8"
Temperature	32°F / 41°F		
Voltage	HP (per deck)	Amps	NEMA
	(¾) 1½	10.6	NEMA-L6-20P
Doors	3		
Shelves	15		

Medium Temp

† Depth does not include 1½" (35 mm) for door handles.

TRM Plan Views

(NOTE: plan views show NN configuration.)

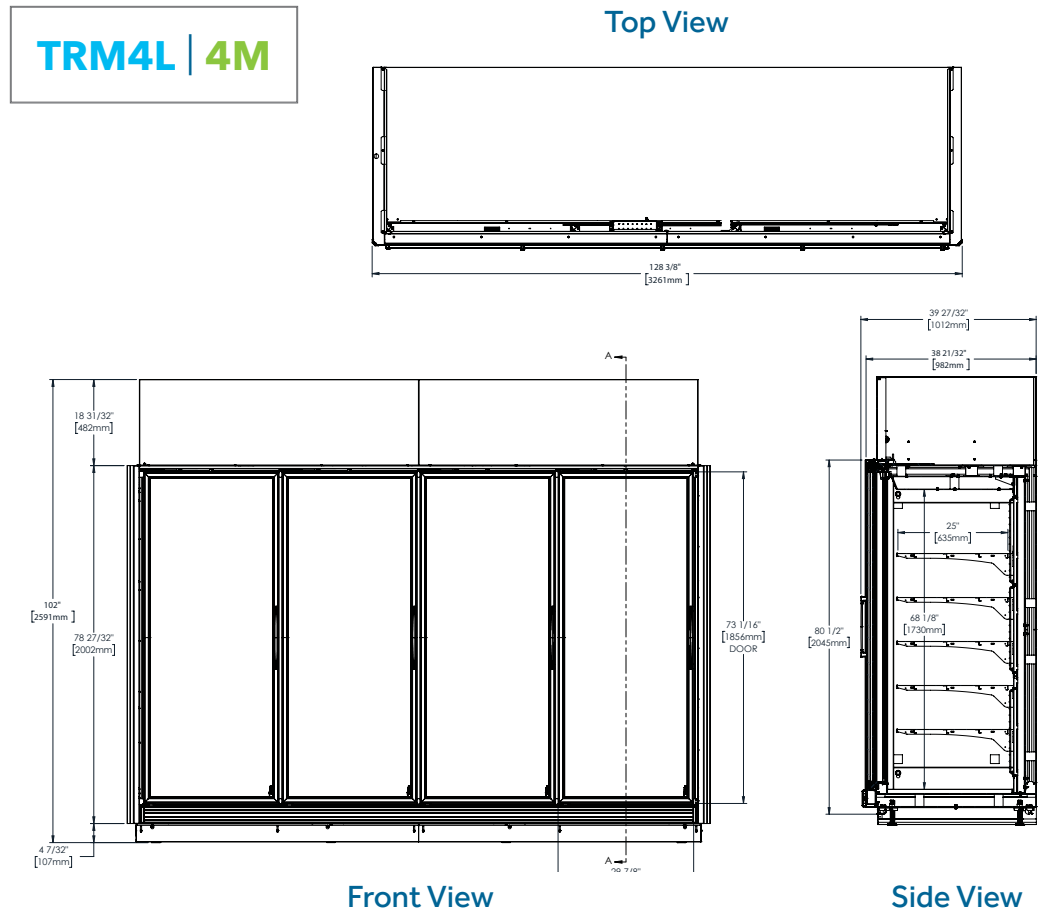

TRM Specifications



TRM4L

Cabinet Exterior Dimensions	W	D†	H
	128 3/8"	38 7/8"	102"
Internal Dimensions	123 1/6"	28"	68 1/8"
Temperature	-10°F / 6°F		
Voltage	HP (per deck)	Amps	NEMA
	(1¼) 3¾	19.6	NEMA-L6-30P
Doors	4		
Shelves	20		

Low Temp



TRM4M

Cabinet Exterior Dimensions	W	D†	H
	128 3/8"	38 7/8"	102"
Internal Dimensions	123 1/6"	28"	68 1/8"
Temperature	32°F / 41°F		
Voltage	HP (per deck)	Amps	NEMA
	(¾) 1 ½	10.6	NEMA-L6-20P
Doors	4		
Shelves	20		

Medium Temp







TRM Series



True[®]
REFRIGERATION



2001 East Terra Lane, O'Fallon, MO 63366-4434, USA **ph** | 636.240.2400 **toll free** | 800.325.6152 **email** | truesales@truemfg.com

truemfg.com